PRODUCT DATA SHEET
C6809

Non-Isolated Uneven Splitters (Taps): Utilized to un-evenly split a single run of 50 Ohm coaxial cable, hosting multiple frequency bands, so that a shorter corridor, tunnel, shaft, or hallway is provided a lesser portion of power on the main coaxial run than that required by a longer run. Non-Isolated Uneven Splitters are Bi-Directional, and unlike Directional Couplers, all ports can communicate with one another.

Features:

High Power Wide Bandwidths Small Size Flat Coupling Custom Designs Available

Electrical Specifications:

Frequency: 2310 - 2350 MHz
 Power: 2000 W CW
 Coupling: 10 ± 1.0 dB Max.
 Insertion Loss: 0.2 dB Max.
 Flatness: ± 0.5 dB Max.
 VSWR (ML): 1.20:1 Max.

Mechanical Specifications:

Type: Connectorized
 Material: Aluminum 6061-T6
 Surface Finish: Chem. Film Per MIL-DTL-5541F
 Type I Class 3 (Yellow Iridite)
 RoHS Compliant Available
 Operating Temperature: -55°C to +75°C
 Storage Temperature: -60°C to +85°C
 Humidity: 95% Non-Condensing
 Size: 3.75 x 3.84"
 Weight: 2.5 lbs.

Port Configurations:

Model	Input (J1)	Output (J2)	Coupled Port (J3)
C6809-293	7/16 Female	7/16 Female	7/8" EIA

Werlatone® Broadband Non-Isolated Uneven Splitters (Taps) are designed to tolerate the most stringent operating conditions associated with Distributive Antenna Systems (DAS).

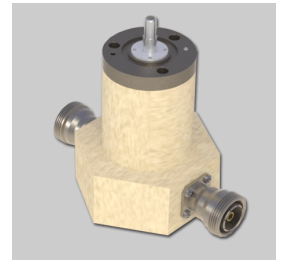

PRODUCT DATA SHEET

C6809

Performance Data (Specifications subject to change without notice):

Coupling:

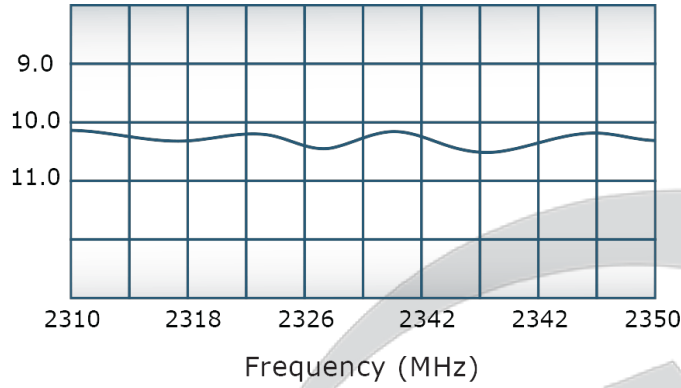

VSWR:

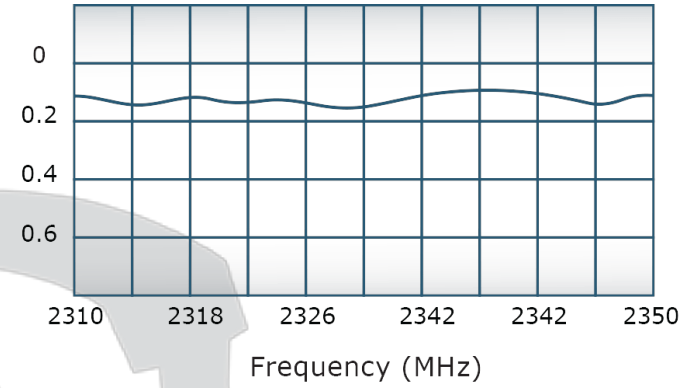

Insertion Loss:

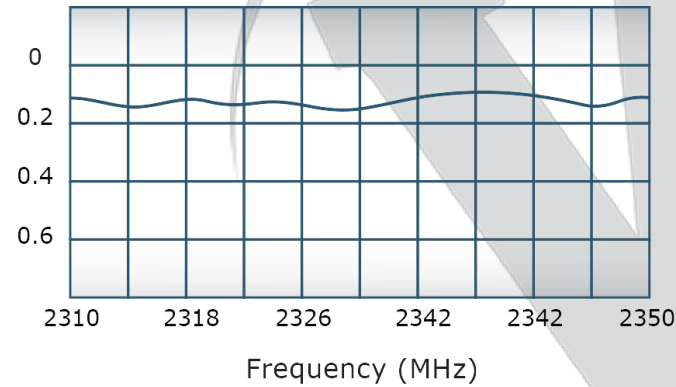

For In-Building Applications



Restriction on use, duplication, or disclosure of proprietary information. This document contains proprietary information which is the sole property of

Werlatone, Inc.

Werlatone, Inc. 17 Jon Barrett Road Patterson, NY 12563 T:(845)278-2220 F:(845)278-3440 sales@werlatone.com www.werlatone.com

DATE	SYM	REVISION RECORD	DR	CK

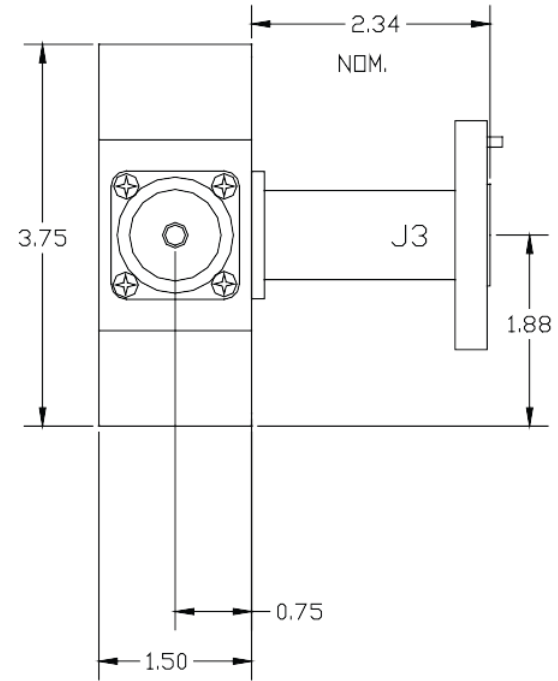
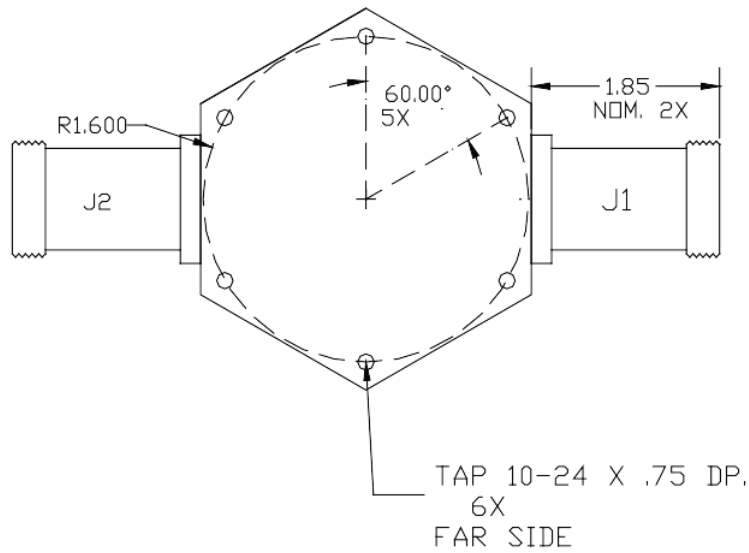

THIS DRAWING CONTAINS INFORMATION
 PROPRIETARY TO WERLATONE INC. AND
 MAY NOT BE USED OR COPIED WITHOUT
 THE WRITTEN CONSENT OF WERLATONE INC.

TOLERANCE	WERLATONE INC.		
XX +/- .015 XXX +/- .005	SCALE	DRAWN BY: SV	APPVD BY: CS
X	TITLE OUTLINE		
	DATE 6/16/00	DRAWING NUMBER 10687-500	

Restriction on use, duplication, or disclosure of proprietary information. This document contains proprietary information which is the sole property of Werlatone, Inc.
 Werlatone, Inc. 17 Jon Barrett Road Patterson, NY 12563 T:(845)278-2220 F:(845)278-3440 sales@werlatone.com www.werlatone.com